

INITIALS: -
 JOB NUMBER: 22415
 DATE: -

MAIN FILE: -
 DEPT: -
 DEALER: -

PRODUCTION APPROVED

- NOTES:
1. OVERALL HEIGHT IS IN LOADED CONDITION. UNLOADED HEIGHTS MAY BE 4" ABOVE HEIGHTS SHOWN.
 2. DO NOT SCALE DRAWING.
 3. ALL DIMENSIONS ARE APPROXIMATE AND SUBJECT TO ENGINEERING CHANGES.
 4. DRAWING MAY OR MAY NOT SHOW ALL ITEMS AS DESCRIBED IN THE WRITTEN DETAIL SPECIFICATIONS.
 5. INCLUSION OF AN ITEM ON THE DRAWING DOES NOT CONSTITUTE INCLUSION OF THAT ITEM WITH THE FINAL DELIVERED UNIT.
 6. THE EFFECTIVE DOOR OPENINGS WILL BE APPROX. 2" LESS THAN THE NOTED COMPARTMENT OPENING FOR ROLL UP DOORS AND UP TO APPROX. 4" LESS FOR HINGED DOORS

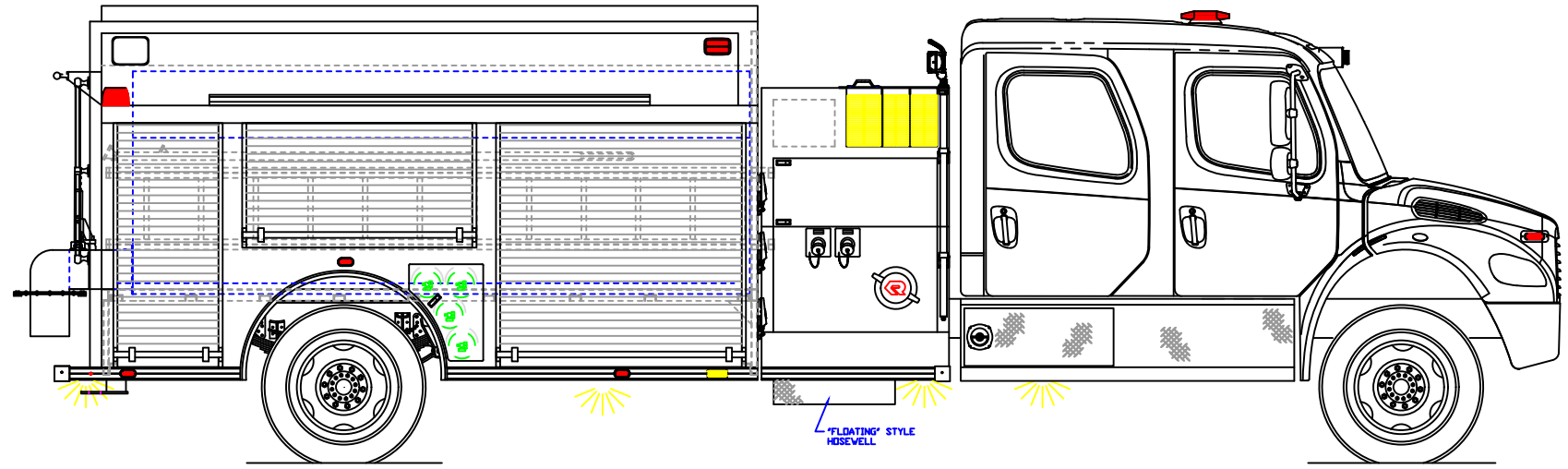
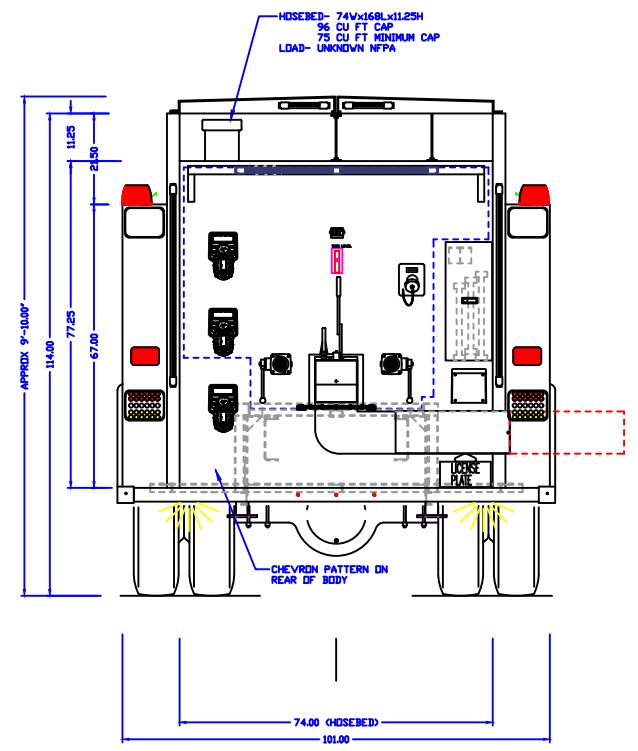
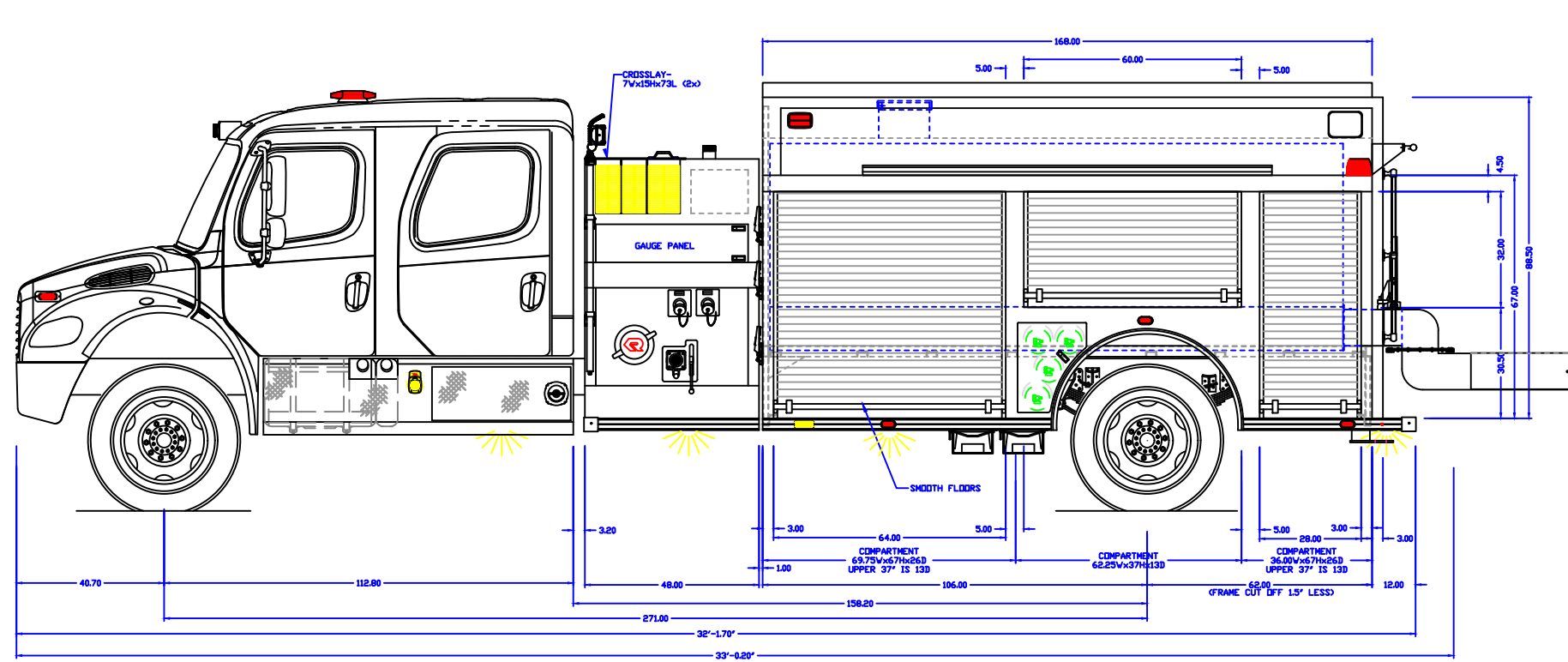
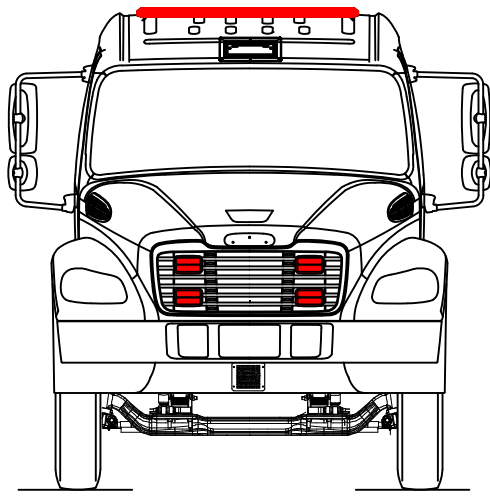

APPROVED BY:

CHASSIS: FREIGHTLINER 2DR
 PUMP: HALE 1250 GPM
 TANK: POLY/2100
 PANEL MATL: STAINLESS STEEL
 COMP INTERIOR: SPATTER PAINTED

REV 1 KA DATE: 9/27/23 UPDATE PER SET BOUND NO CHANGE TO VAP
 REVISED: BVZ DATE: 6/14/23
 DRAWN: BVZ DATE: 5/3/23

PROPRIETARY AND CONFIDENTIAL THE INFORMATION CONTAINED IN THIS DRAWING IS THE SOLE PROPERTY OF ROSENBAUER. ANY REPRODUCTION IN PART OR AS A WHOLE WITHOUT THE WRITTEN PERMISSION OF ROSENBAUER IS PROHIBITED.

MAXIMUM HEIGHT	NONE
MAXIMUM LENGTH	NONE
BODY WIDTH	101"

WASHINGTON CO., FL



ROSENBAUER FX 1/8"

DRAWING NUMBER: WASHINGTON CO., FL REV 1